

MQ-9 Semiconductor Sensor for CO/Combustible Gas

Sensitive material of MQ-9 gas sensor is SnO₂, which with lower conductivity in clean air. It make detection by method of cycle high and low temperature, and detect CO when low temperature (heated by 1.5V). The sensor's conductivity is more higher along with the gas concentration rising. When high temperature (heated by 5.0V), it detects Methane, Propane etc combustible gas and cleans the other gases adsorbed under low temperature. Please use simple electrocircuit, Convert change of conductivity to correspond output signal of gas concentration.

MQ-9 gas sensor has high sensitivity to Carbon Monoxide, Methane and LPG. The sensor could be used to detect different gases contains CO and combustible gases, it is with low cost and suitable for different application.

Character

- * Good sensitivity to CO/Combustible gas
- * High sensitivity to Methane, Propane and CO
- * Long life and low cost
- * Simple drive circuit

Application

- * Domestic gas leakage detector
- * Industrial gas detector
- * Portable gas detector

Technical Data

Configuration

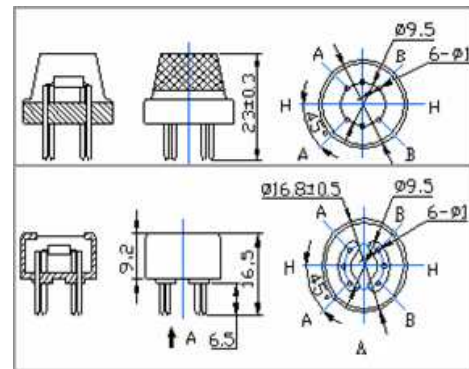

Basic test loop

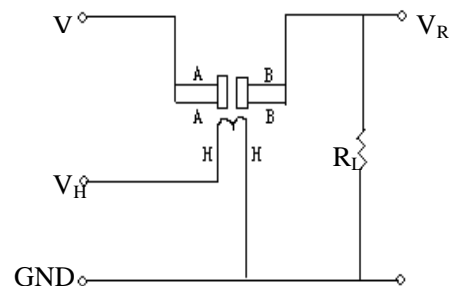

The above is basic test circuit of the sensor. The sensor need to be put 2 voltage, heater voltage (V_H) and test voltage (V_C). V_H used to supply certified working temperature to the sensor, while V_C used to detect voltage (V_R) on load resistance (R_L) whom is in series with sensor. The sensor has light polarity, V_c need DC power. V_C and V_H could use same power circuit with precondition to assure performance of sensor. In order to make the sensor with better

Model No.		MQ-9	
Sensor Type		Semiconductor	
Standard Encapsulation		Bakelite	
Detection Gas		CO and combustible gas	
Concentration		10-1000ppm CO 100-10000ppm combustible gas	
Circuit	Loop Voltage	V _c	≤10V DC
	Heater Voltage	V _H	5.0V±0.2V AC or DC (High) 1.5V±0.1V AC or DC (Low)
	Heater Time	T _L	60±1S (High) 90±1S (Low)
	Load Resistance	R _L	Adjustable
Character	Heater Resistance	R _H	31Ω±3Ω (Room Tem.)
	Heater consumption	P _H	≤350mW
	Sensing Resistance	R _s	2KΩ-20KΩ(in 100ppm CO)
	Sensitivity	S	R _s (in air)/R _s (100ppm CO) ≥5
	Slope	α	≤0.6(R _{300ppm} /R _{100ppm} CO)
Condition	Tem. Humidity	20°C±2°C; 65%±5%RH	
	Standard test circuit	V _c : 5.0V±0.1V; V _H (High) : 5.0V±0.1V; V _H (Low) : 1.5V±0.1V	
	Preheat time	Over 48 hours	

performance, suitable R_L value is needed:

$$\text{Power of Sensitivity body (Ps): } P_s = V_c^2 \times R_s / (R_s + R_L)^2$$

Resistance of sensor(R_s): $R_s=(V_c/V_{RL}-1)\times R_L$

Sensitivity Characteristics

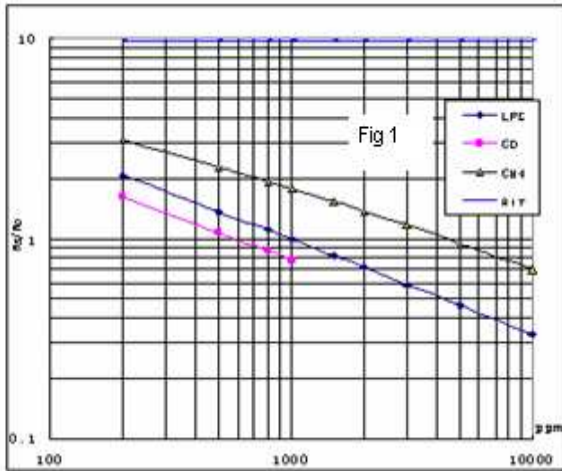

Fig.1 shows the typical sensitivity characteristics of the MQ-9, ordinate means resistance ratio of the sensor (R_s/R_o), abscissa is concentration of gases. R_s means resistance in different gases, R_o means resistance of sensor in 1000ppm LPG. All test are under standard test conditions.

Influence of Temperature/Humidity

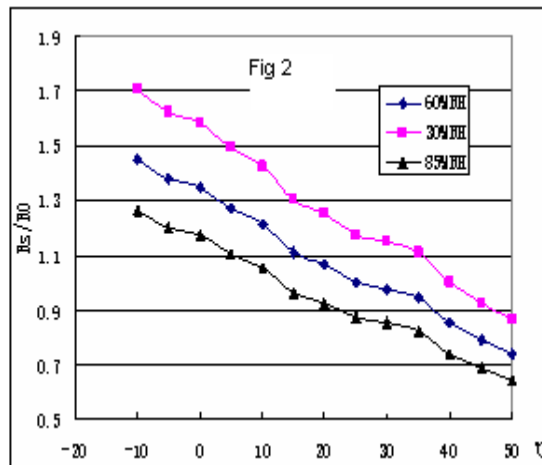
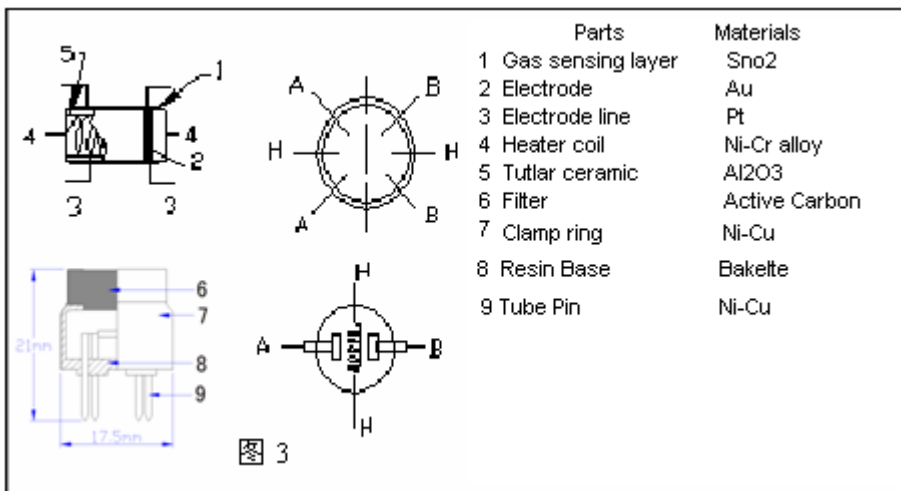

Fig.2 shows the typical temperature and humidity characteristics. Ordinate means resistance ratio of the sensor (R_s/R_o), R_s means resistance of sensor in 1000ppm Propane under different tem. and humidity. R_o means resistance of the sensor in environment of 1000ppm Propane, 20°C/65%RH

Structure and configuration



Structure and configuration of MQ-9 gas sensor is shown as Fig. 3, sensor composed by micro AL2O3 ceramic tube, Tin Dioxide (SnO2) sensitive layer, measuring electrode and heater are fixed into a crust made by plastic and stainless steel net. The heater provides necessary work conditions for work of sensitive components. The enveloped MQ-7 have 6 pin, 4 of them are used to fetch signals, and other 2 are used for providing heating current.

Notification

1 Following conditions must be prohibited

1.1 Exposed to organic silicon steam

Organic silicon steam cause sensors invalid, sensors must be avoid exposing to silicon bond, fixture, silicon latex, putty or plastic contain silicon environment

1.2 High Corrosive gas

If the sensors exposed to high concentration corrosive gas (such as H_2S , SO_x , Cl_2 , HCl etc), it will not only result in corrosion of sensors structure, also it cause sincere sensitivity attenuation.

1.3 Alkali, Alkali metals salt, halogen pollution

The sensors performance will be changed badly if sensors be sprayed polluted by alkali metals salt especially brine, or be exposed to halogen such as fluorin.

1.4 Touch water

Sensitivity of the sensors will be reduced when splattered or dipped in water.

1.5 Freezing

Do avoid icing on sensor's surface, otherwise sensor would lose sensitivity.

1.6 Applied voltage higher

Applied voltage on sensor should not be higher than stipulated value, otherwise it cause down-line or heater damaged, and bring on sensors' sensitivity characteristic changed badly.

1.7 Voltage on wrong pins

For 6 pins sensor, if apply voltage on 1、3 pins or 4、6 pins, it will make lead broken, and without signal when apply on 2、4 pins

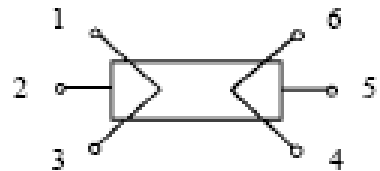

2 Following conditions must be avoided

2.1 Water Condensation

Indoor conditions, slight water condensation will effect sensors performance lightly. However, if water condensation on sensors surface and keep a certain period, sensor' sensitivity will be decreased.

2.2 Used in high gas concentration

No matter the sensor is electrified or not, if long time placed in high gas concentration, if will affect sensors characteristic.

2.3 Long time storage

The sensors resistance produce reversible drift if it's stored for long time without electrify, this drift is related with storage conditions. Sensors should be stored in airproof without silicon gel bag with clean air. For the sensors with long time storage but no electrify, they need long aging time for stbility before using.

2.4 Long time exposed to adverse environment

No matter the sensors electrified or not, if exposed to adverse environment for long time, such as high humidity, high temperature, or high pollution etc, it will effect the sensors performance badly.

2.5 Vibration

Continual vibration will result in sensors down-lead response then repture. In transportation or assembling line, pneumatic screwdriver/ultrasonic welding machine can lead this vibration.

2.6 Concussion

If sensors meet strong concussion, it may lead its lead wire disconnected.

2.7 Usage

For sensor, handmade welding is optimal way. If use wave crest welding should meet the following conditions:

2.7.1 Soldering flux: Rosin soldering flux contains least chlorine

2.7.2 Speed: 1-2 Meter/ Minute

2.7.3 Warm-up temperature: $100\pm 20^{\circ}C$

2.7.4 Welding temperature: $250\pm 10^{\circ}C$

2.7.5 1 time pass wave crest welding machine

If disobey the above using terms, sensors sensitivity will be reduced.