



NDIR Infrared CO2 Gas Sensor

(Model: MH-410D)

Manual

Version: 2.7

Valid from: 2016.5.05

Zhengzhou Winsen Electronics Technology Co., Ltd

Statement

This manual copyright belongs to Zhengzhou Winsen Electronics Technology Co., LTD. Without the written permission, any part of this manual shall not be copied, translated, stored in database or retrieval system, also can't spread through electronic, copying, record ways.

Thanks for purchasing our product. In order to let customers use it better and reduce the faults caused by misuse, please read the manual carefully and operate it correctly in accordance with the instructions. If users disobey the terms or remove, disassemble, change the components inside of the sensor, we shall not be responsible for the loss.

The specific such as color, appearance, sizes &etc, please in kind prevail.

We are devoting ourselves to products development and technical innovation, so we reserve the right to improve the products without notice. Please confirm it is the valid version before using this manual. At the same time, users' comments on optimized using way are welcome.

Please keep the manual properly, in order to get help if you have questions during the usage in the future.

Zhengzhou Winsen Electronics Technology CO., LTD

MH-410D NDIR Infrared CO2 Sensor

Introduction

MH-410D infrared gas sensor is a miniature universal intelligent sensor, which adopts NDIR theory to detect concentration of CO₂ in air and has good selectivity, stable performance, long life, also is independent of Oxygen. The inside temperature sensor could be used for temperature compensation. This miniature infrared gas sensor is developed by the tight integration of mature infrared absorbing gas detection technology, micro machine workout and superior circuit design.



Features

- High sensitivity, high resolution, low power consumption
- Output method: UART, analog voltage signal
- Fast response time
- Temperature compensation, excellent linear output
- Excellent stability,
- Long lifespan
- Anti-poisons, anti-vapor interference

Applications

Widely used for HVAC refrigeration, air monitoring indoor, industrial-process control and safety protection, agriculture and animal husbandry.

Main Parameters

Fig1

Model	MH-410D
Detection Gas	CO ₂
Working Voltage	3.6~5V DC
Average Current	<85 mA
Interface Level	3.0V
Detection range	0-5%vol Optional(refer Fig2.)
Output Signal	UART
	0.4~2V
Warm-up time	3 min
Response time	T90<30s
Working Temperature	-20°C ~60°C
Working Humidity	0~95%RH(no condensation)
Sizes	Φ20x21.4mm
Weight	35g
Lifetime	>5 years
Defense Grade	IP54

Fig2.Measuring Range and Resolution

Target Gas	Measuring Range	Accuracy	Note
CO2	0~2000 ppm	±(50ppm + 5% of Read Value)	Temperature compensation
	0~6000 ppm		Temperature compensation
	0~1% VOL		Temperature compensation
	0~3% VOL		Temperature compensation
	0~5%VOL		Temperature compensation

Structure Size

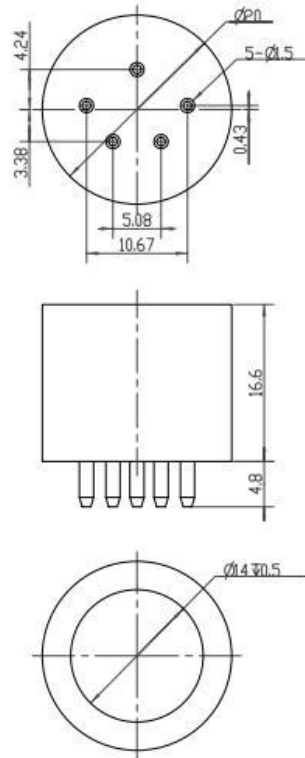

Picture 1.Sensor structure

■ **Pin definition**

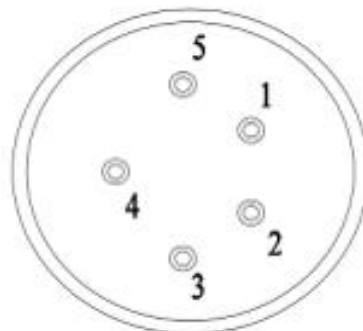

Picture 2.Pin definition

Fig3.Pin definition

Name of Pin	Explanation
Pin 2	Vin Voltage input
Pin 1	GND
Pin 4	Vout (0.4~2 V)
Pin 3	UART (RXD) 0~3.0 V data input
Pin 5	UART (TXD) 0~3.0 V data output

6.Application circuit

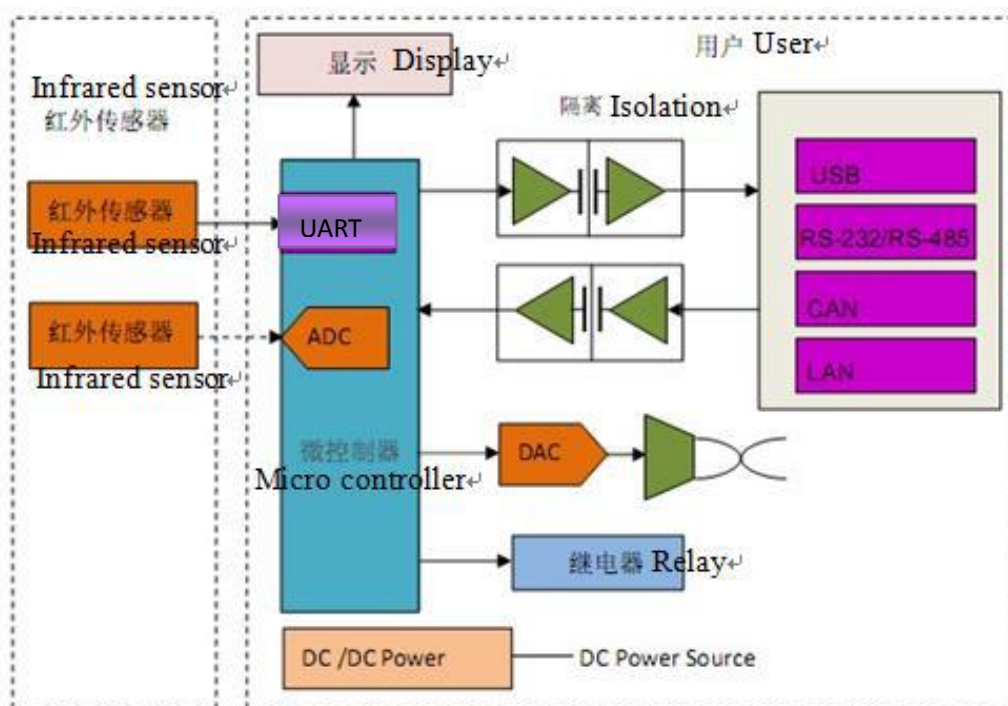

6.1 Analog voltage output

The output of Vout is proportional to the gas concentration, 0.4-2.0V output stands for 0 to full range.

Connection: Vin -5V,GND- Power Ground, Vout-ADC input.

After warm-up, If self-checking detect a fault, output voltage is 0V.

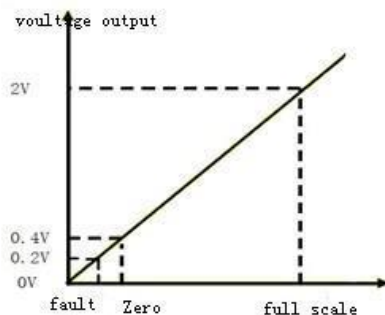

6.2 Digital Output(UART)

6.2.1 Hardware Connections:

Connect the Vin-GND-RXD-TXD of the sensor to the user's 5V-GND-TXD-RXD one to one correspondence.(The client must use a TTL level, and if it is an RS232 level, it must be converted).Users can read gas concentration via UART interface of sensor.No need to calculate..

6.2.2 Software settings

Set the serial baud rate to 9600, the data bit to 8 bits, the stop bit to 1 bit, the parity bit set to none.

Protocol command interface list and meaning	
0x86	Reading gas concentration value
0x87	Calibrate sensor (ZERO)
0x88	Calibrate sensor (SPAN)

General setting

Baud rate	9600
Data bit	8 bit
Stop bit	1 bit
Check bit	Null

Command

Every piece of command and return:

Each command includes 9 byte(byte0~byte8)

beginning with 0xff,

command includes sensor no.(default is 0x01),

ending with checksum ,

Command list

0x86	Reading gas concentration value
0x87	Calibrate sensor zero point(ZERO)
0x88	Calibrate span point(SPAN)

0x86-Reading gas concentration value								
Send command								
Byte 0	Byte 1	Byte 2	Byte 3	Byte 4	Byte 5	Byte 6	Byte 7	Byte 8
Start bit	Sensor no.	Command	-	-	-	-	-	checksum
0xFF	0x01	0x86	0x00	0x00	0x00	0x00	0x00	0x79
Returning								
Byte 0	Byte 1	Byte 2	Byte 3	Byte 4	Byte 5	Byte 6	Byte 7	Byte 8
Start bit	command	Concentration high-position	Concentration low-position	-	-	-	-	checksum
0xFF	0x86	0x02	0x60	0x47	0x00	0x00	0x00	0xD1
The concentration calculation method: For 0-2000ppm/0-6000ppm, CO2 Concentration (unit is ppm)=Concentration high-position*256+Concentration low-position								

For 0-1%vol/0-3%vol/0-5%vol,
CO2 concentration (unit is %VOL)=(Concentration high-position*256+Concentration low-position)/100

Calibrate zero

0x87-Calibrate sensor zero point								
Send command								
Byte0	Byte1	Byte2	Byte3	Byte4	Byte5	Byte6	Byte7	Byte8
Start bit	Sensor no.	Command	-	-	-	-	-	checksum
0xFF	0x01	0x87	0x00	0x00	0x00	0x00	0x00	0x78
The sensor has no return value								

0x88-Calibrate span point								
Byte0	Byte1	Byte2	Byte3	Byte4	Byte5	Byte6	Byte7	Byte8
Start bit	Sensor no.	Command	Concentration high-position	Concentration low-position	-	-	-	checksum
0xFF	0x01	0x88	0x07	0xD0	0x00	0x00	0x00	0xA0
The sensor has no return value								

Checksum calculation method								
checksum = (negation (byte1+byte2+.....+byte7))+1								
Example:								
Byte0	Byte1	Byte2	Byte3	Byte4	Byte5	Byte6	Byte7	Byte8
Start bit	Sensor no.	Command	-	-	-	-	-	checksum
0xFF	0x01	0x86	0x00	0x00	0x00	0x00	0x00	checksum
计算如下:								
1、from Byte1 to Byte7: 0x01 + 0x86 + 0x00 + 0x00 + 0x00 + 0x00 + 0x00 = 0x87								
2、invert: 0xFF - 0x87 = 0x78,add 1 to above value 0x78 + 0x01 = 0x79								
C language calculation checksum routines								
<pre> char getCheckSum(char *packet) { char i, checksum; for(i = 1; i < 8; i++) { checksum += packet[i]; } checksum = 0xff - checksum; checksum += 1; return checksum; } </pre>								

Cautions

- The sensor should be calibrated regularly. The suggested cycle time is 6 months.
- Do not use the sensor in the high dusty environment for long time.